

Samsung iDCS SLiM

Single-Line Integrated Mobility

Handset User Guide

April 2005

Samsung Telecommunications America reserves the right without prior notice to revise information in this guide for any reason. Samsung Telecommunications America also reserves the right without prior notice to make changes in design or components of equipment as engineering and manufacturing may warrant. Samsung Telecommunications America disclaims all liabilities for damages arising from the erroneous interpretation or use of information presented in this guide.

Copyright 2005 Samsung Telecommunications America.

All rights reserved. No part of this manual may be reproduced in any form or by any means—graphic, electronic or mechanical, including recording, taping, photocopying or information retrieval systems—without express written permission of the publisher of this material.

TABLE OF CONTENTS





QUICK REFERENCE	1
CONSTRUCTION	2
BATTERY INSTALLATION	3
CHARGING	4
KEY FUNCTIONS	5
TURNING THE HANDSET ON/OFF	6
MAKING A CALL	7
Receiving Calls	8
During a Conversation	8
Volume Adjust	8
Microphone Mute	8
Transferring the Call to Another Handset.....	9
PROFILES (Set-Ups)	10
MENU STRUCTURE	11
Using the Alphanumeric Keyboard	12
Key Functions	12
Profile Setup	13
Profile Functions	14
Menu Subscription and Login	15
Create Subscription	16
Login	16
Auto Login	17
Remove Subscription	17
Change Startup Text.....	18
Battery Capacity.....	18
Redial	19

Book	20
External Services	21
MSF Functions	21
Mail / Text Messages	21
Menu Structure	23
Menu Language	24

SHORTCUTS	25
------------------------	----

INFORMATION	26
Troubleshooting	26
Error Information	26
Technical Information	26
Approvals	26
Size and Weight	27
Capacity	27
Safety Instructions	27
Important Safety Instructions and Product Information	27
Intrinsic Safety	28
Exposure to Sunlight, Heat and Moisture.....	28
Battery Disposal	29
Spare Parts and Accessories	29
Power Failure.....	29
Battery Precautions.....	29
Notices and Cautions.....	30-31

QUICK REFERENCE

- **ON:** Press  for 1/2 seconds turn on your handset.
- **OFF:** Press the **OK** key for 3 seconds to turn off your handset.
- **LOCK/UNLOCK:** Press  * to to lock/unlock your handset.
- **VOLUME ADJUST:** Use the two keys placed at the right side of the handset for volume control.
- **MICROPHONE MUTE:** Press **OK** key, "MIC MUTED" is shown in the display. Press **OK** to enable the microphone again.
- **RINGER MUTE WITHOUT ANSWERING CALL:** When the phone is ringing press the **OK** key and the ringing signal is muted. The display shows: "RINGER MUTED".
- **RECEIVING CALLS:** If the phone rings, the call can be answered by pressing the  key.
- **REDIAL:** Press the < key to enter the redial/CLIP stack.
- **"R" ** : If off hook this key acts as a flash function. If on hook: reads a message.
- **"<":** When editing press and hold to delete the last digit. When on hook press to display last outgoing calls.

CONSTRUCTION

Your Samsung iDCS SLiM handset will provide you with the greatest possible degree of flexibility and mobility due to high battery capacity, practical weight, size and design.



BATTERY INSTALLATION

Before using the telephone it is important that you connect the battery to the connector in the battery box. Assemble the battery cover as described below and place the handset into the charger.

- Push the battery cover 5 mm towards the headset plug using your thumbs.
- Lift off battery cover.
- If the battery is not already installed, place battery plug in the slot in the battery box.
- Place the battery plug in the slot with red wire closest to the left (see Rear View below).
- Insert battery with the label readable and replace cover.



Handset Rear View

CHARGING

It takes approximately 3 1/2 hours to charge the handset from fully discharged to its full capacity. Place the handset in the charger. The display shows the charging status in line 3. For correct charging the room temperature has to be between 0°C and 25°C and therefore the handset must not be placed in direct sunshine. The battery has a built-in heat sensor which will stop the charging if the battery temperature is too high.

It is necessary to recharge the battery when the display shows "BATTERY LOW", or if it cannot be turned on. The LED flashes at a low frequency while charging and lights constantly when the charging has finished. The display goes back to normal mode when fully charged.

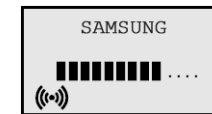









When the handset is placed in the charger the vibrator will not work and the B-answer function is inactive even if chosen. If the battery is fully discharged, it will be a moment before charging starts.

KEY FUNCTIONS

The handset has 21 keys.

Two keys are placed at the right side for volume control. Press upper or lower key to change the volume. Each key press turns volume one step up/down.

	Go to Menu Structure or Exit Menu Structure (Escape or »NO«.
"<";  /C	Menu: Left, Cursor Left, press and hold to delete last digit. Long press: delete all. From standby text: Redial Menu.
">"; 	Menu: Right, Cursor Right, After a Digit: Store number in telephone book. From standby text: Telephone book read.
"OK"; 	Confirmation (»YES«) or jump to next level in the menu. In off hook: Mute. Long key press turns the handset OFF.
"ALT"; 	If residential systems: Internal calls off hook, and internal recall if already off hook.
"R"; 	If off hook this key acts as a flash function. If on hook: Read message.
	On hook, off hook and turn ON.
*; 	* Long = pause (—), extra long: change from pulse to DTMF ("T" appears in the display, GAP standard).
0 - 9	Digits or letters in alphanumeric mode (names and messages).
#	#, Choose uppercase or lowercase letters in alphanumeric mode.

TURNING THE HANDSET ON/OFF

ON: Press  key for 1/2 second.



When the handset is turned on the  symbol is shown in the lower left corner of the display, if the handset is subscribed to a system (please refer to the Create Subscription section of this user guide).

OFF: Press the **OK** (MUTE) key for 3 seconds.

Please note: When the handset has been outside the coverage area, it can take up to 30 seconds before the handset is back on the system after re-entering the coverage area.

MAKING A CALL

For making or receiving calls the handset has to be subscribed to a system ((☎)) shown in the display, [see Create Subscription section](#).



Press the  key, the  icon in the display will flash until connection is established.

Dial the number.

Pre-Dial

Press the number to dial (long press on * will make a pause, if necessary)



Press and hold < key to delete last digit.

Press the  key, the  icon in the display will flash until connection is established.

Telephone Book

Press the > key  to enter the telephone book.

Search for the number either by using the < key or the > key or by pressing the first letter in the name by using the digits **1-9** (refer to the Key Functions section).



Press the  key, the  icon in the display will flash until connection is established.

Redial

Redial / CLIP (CLIP = Calling Line Identification Presentation) stack:

Press the < key /C to enter the redial/CLIP stack.

Search for the number by using the < key or the > key, redialed numbers are marked with REDIAL or name and clip numbers are marked either with CLIP or the name of the person who called and the LED is on.

Press the  key, the  icon in the display will flash until connection is established.

Using the handset on residential systems:



Internal Call Post-Dial:

Press the **ALT** key , the icon  in the display will flash.

Dial the number of another handset on the base station, the  icon will flash until the connection is established.

Internal Call Pre-Dial:

Press the number of another handset on the base station.

Press the **ALT** key , the  icon will flash until the connection is established.

RECEIVING CALLS

If the phone rings, the call can be answered by pressing the  key.

When ringing the LED flashes fast, and the display shows the CLIP (if presented). If it is an external call (or if no CLIP) the display shows: "INCOMING CALL"

It is possible to stop the ringing signal without answering the call. Press the **OK** key () and the ringing signal is muted. The display shows: "RINGER MUTED"

If the handset is used with a headset, it is possible to answer a call by pressing any key on the handset.

DURING A CONVERSATION

Volume Adjust

Use the two keys placed at the right side of the handset for volume control.

Microphone Mute

Press the **OK** key (), MIC. MUTED is showed in the display.



Press the **OK** key () to enable the microphone again.



Transferring the Call to Another Handset

Press **R**, and dial the new number.

Press the  key and the call is transferred to the other handset.

PROFILES (Set-Ups)

The handset has two user-defined profiles (set ups), and a mode where all sounds are disabled (SILENT). Pressing the  followed by **OK** will show the chosen profile. A new profile can be selected by using the arrow keys. To select the chosen profile press **OK**. To escape (without storing anything) press  again.

A quick way of choosing a profile, is to press  and then **1, 2** or **#** (1 is the Profile 1, 2 is the Profile 2 and # is SILENT). To change the set up in a profile, press  followed by the **OK** twice. All settings have to be defined under each of the two profiles. The display shows if the SILENT mode or PROFILE2 is chosen.



MENU STRUCTURE

Pressing the  key, enters or exits the menu structure. It has to be used if a “NO” or “CLEAR” is wanted in the menu structure.

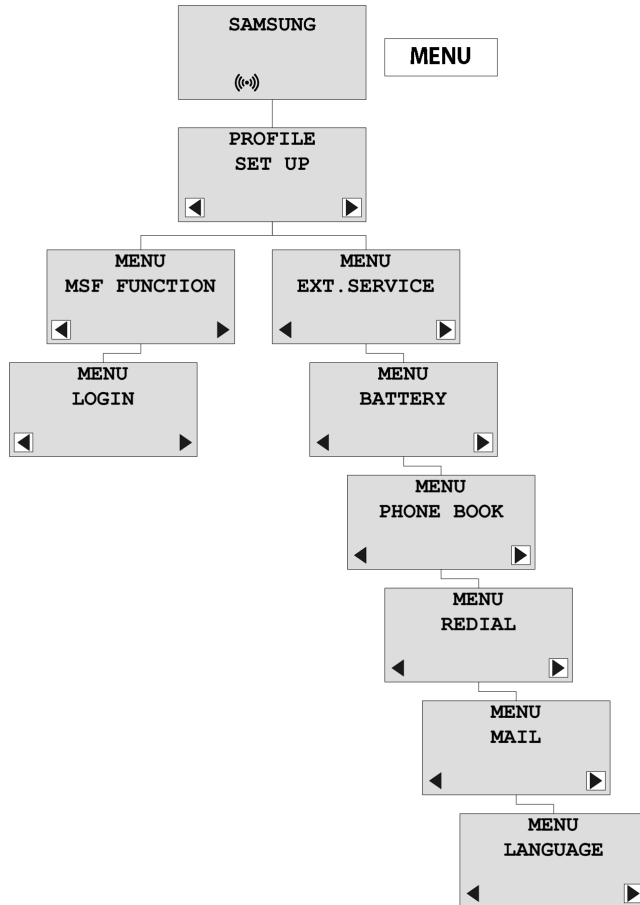
Pressing the **OK** key, jumps to a lower level in the menu. When the lowest menu level is reached, it will store the setting and jump to a higher level. It has to be used if a “YES” is wanted.



The phone book and redial menu can be accessed directly.

The phone book by pressing the >  key and the redial menu by pressing the < key .

USING THE ALPHANUMERIC KEYBOARD

The normal dialing keys (**0-9**) are used for writing the name to be placed in the phone book. By pressing the keys a certain number of times the related letters or digits will appear in the display. Spaces are made by using the **0** key. Key **#** changes between uppercase and lowercase. The arrows will move the cursor. Left arrow is also used for deleting (hold for 1 second) = delete. New letters can be inserted.

Change of key press and pauses lasting more than 1 second automatically moves the cursor to the next position.

KEY FUNCTIONS

Key	
1	Æ Ø Å @ Ä Ö ß Ü 1
2	A B C @ Ä Á À Â 2
3	D E F 3
4	G H I ï Î 4
5	J K L 5
6	M N O Ö Ó Ò 6
7	P Q R S ß 7
8	T U V Ü Ú Û Ü 8
9	W X Y Z 9
0	Space . , _ - + : ? ! 0
*	* # / \ () = &
#	Upper/lower case

PROFILE SETUP

In the following you will find a description of how to set up one of the 2 profiles. To enter the Profile Set-Up menu press **■**. Then press **OK** and use **>** or **<** to find the profile you wish to change and confirm with **OK**. You are now able to switch between the different settings. Press **OK** when you find the setting you wish to change. Change the setting according to your needs, confirm with the **OK** key and automatically you go to the next setting. Press the **■** key to finalize the profile setup.

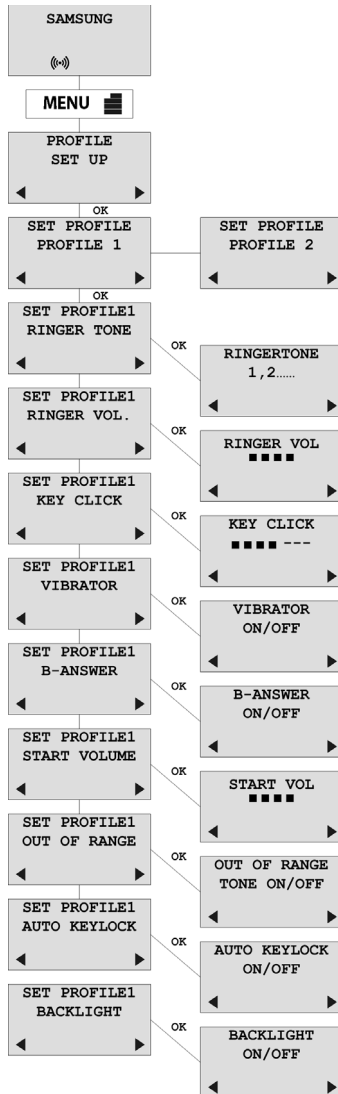

PROFILE FUNCTIONS

BACKLIGHT: Can be turned on/off using the **>** and **<**. Confirm with **OK**.

RINGERTONE: Scroll through the 9 different ringtones using **>** and **<**. Confirm with **OK**.

RINGER VOLUME: Turn the volume up and down using **>** and **<**. Confirm with **OK**.

KEY CLICK: Turn the volume up and down using **>** and **<**. Confirm with **OK**.

VIBRATOR: Can be turned on/off using **>** and **<**. Confirm with **OK**.

B-ANSWER: Can be turned on/off using **>** and **<**. Confirm with **OK**. When turned on, the telephone automatically goes off hook when ringing. If subscribed to the system it automatically goes on hook when calls are terminated.

REMARK: Automatically on-hook is only reliable under defined conditions related to the interface settings between the Control Unit and the PBX.

START VOL: Start volume can be adjusted using the **>** and **<**. Confirm with **OK**.

OUT OF RANGE: The out of range indication can be turned on/off using the **>** and **<**. Confirm with **OK**. With the out of range indicator turned on, a beep will appear when the telephone is moving out of range of the base station, and "OUT OF RANGE" will appear in the display.

AUTO KEYLOCK: The auto keylock function can be turned on/off using the **>** and **<**. Confirm with **OK**. With auto keylock turned on the handset will automatically lock the keys after 60 seconds. Press **■ *** to activate the keys again.

MENU SUBSCRIPTION AND LOGIN

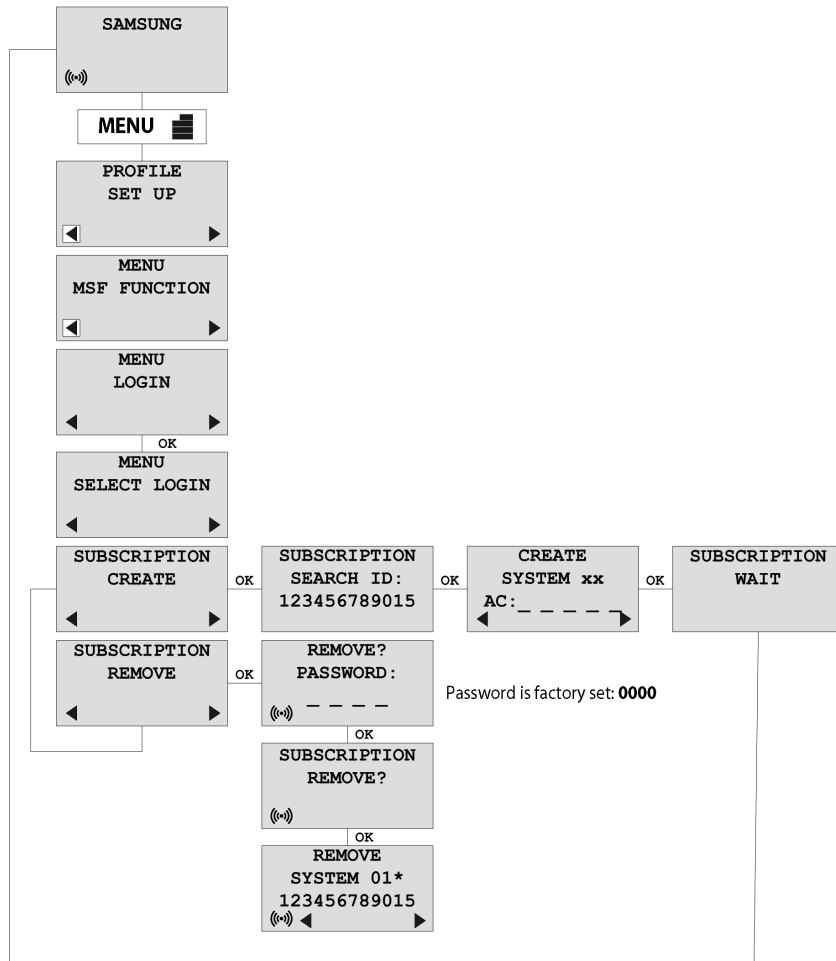

Create a Subscription

To make subscriptions, the system must allow subscriptions to be made. Some systems also require an Access Code (AC). If more than one system currently permits subscription, you will need to know the ID of the system to which you wish to subscribe. Access Codes and system ID's will be provided by the system administrator.

Choose the SUBSCRIPTION CREATE menu to subscribe to a new system (refer to the diagram on previous page).

Use the < and > keys to scroll between the ID's of the different systems available.

During subscription the handset will search for free positions and perform subscription on the first free position. An alternative position can be chosen using < or >. Give in the AC (if required) using the keyboard, and press OK. If the subscription was successful, the startup text will be replaced by the standby text given into the system by the system administrator and is shown in the display. If not, the subscription has failed and the procedure must be retried.

If the handset is already subscribed to 10 systems, you will have to remove a subscription before creating a new subscription (refer to [Remove Subscription](#)).

Login

The handset can be subscribed to 10 different systems enabling you to use the same handset on 10 different systems.

If you would like to change to another system, use the login menu to connect to another system number. The actual chosen system is shown with the red LED on.

To change to another system use < or > and press **OK** to confirm.

To be able to log on to a system, subscription to the system has to be established (see [Create a Subscription](#)).

Under LOGIN/SELECT LOGIN only subscriptions will be shown. Free positions will not be shown.

Auto Login

The handset can be subscribed to 10 different systems. If Auto Login is chosen from the menu, the handset automatically selects a system. The selected system is marked with an "A".

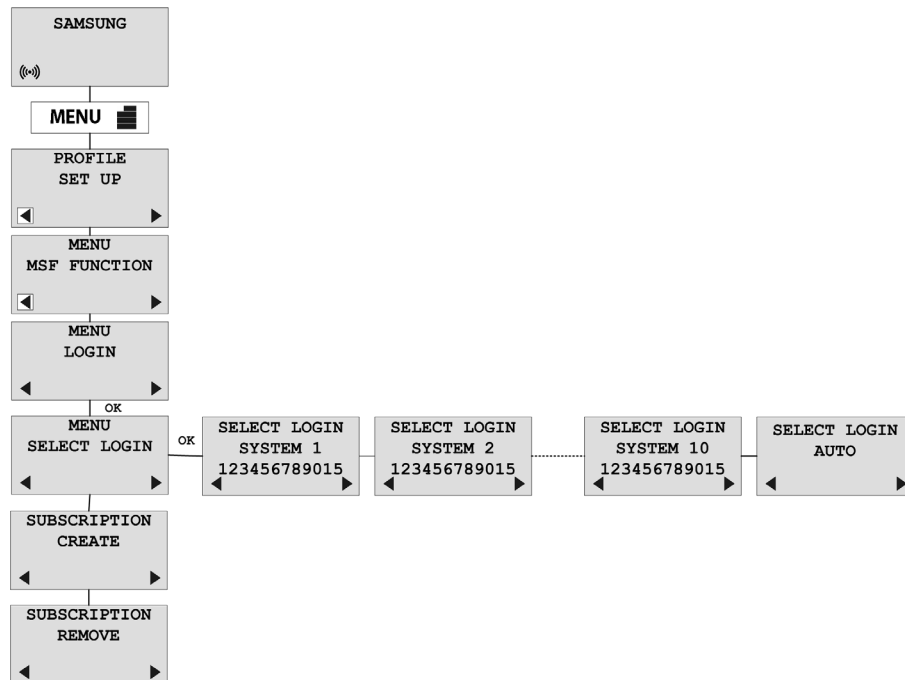

Please note: Auto login should only be used in separate systems without overlaps.

Remove Subscription

Subscriptions can be removed from the system in use and from the 9 other systems (if connected). Removing a subscription requires a password. Password is factory set at 0000. If the system in use is removed, it is necessary either to select one of the remaining systems or to subscribe to a new one. If one of the systems not chosen is removed, the handset remains connected to the system in use.

Change Startup Text

The startup text is predefined as i.e. "Samsung" as factory default. This can be changed by using the following procedure:

Press ******, BOOK**, and the OK key. Enter the new startup text by using the keys (refer to the Key Functions) followed by the **OK** key. It is possible to enter 24 characters.

Battery Capacity

In the battery menu it is possible to see the remaining battery capacity. For reading the correct capacity, the handset has to be removed from the charger for at least one hour.

Press **☰** and use the > or < keys to reach the Battery Menu.

Press **OK** to enter the menu, and you can see the current status of the battery capacity. Press **OK** to return to the menu system or press **☰** to quit.

The indication on the display is not necessarily an exact reflection on the remaining speech time, but only an indication of the voltage on the battery.

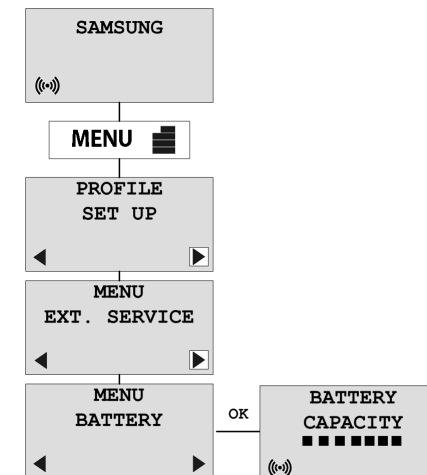

Redial

The handset has maximum 10 redial numbers and 10 Caller ID's placed in the same stack. Each number is only represented once. Enter the redial menu by pressing < (Redial) from the standby text. Repeated presses at the < button turn backward through the dialed numbers and CLIP numbers (from newest to the oldest). Right arrow moves in the opposite direction. It is also possible to reach the redial menu in the main menu. Numbers are named "REDIAL","CLIP" or with the name.

The LED will flash slowly if a new number (unanswered call) has arrived in the CLIP stack. If no number (no CLIP) is represented by a call only the LED will flash slow afterwards.

If you want to delete a "CLIP" or a "REDIAL" you scroll to the name/number and press **OK** twice.

The name/number is now deleted. If a number is stored, it is moved to the telephone book.

It is possible to edit the CLIP or redial numbers. Find the number you wish to edit and press the digits you want to add to the number, e.g. prefix = 0.

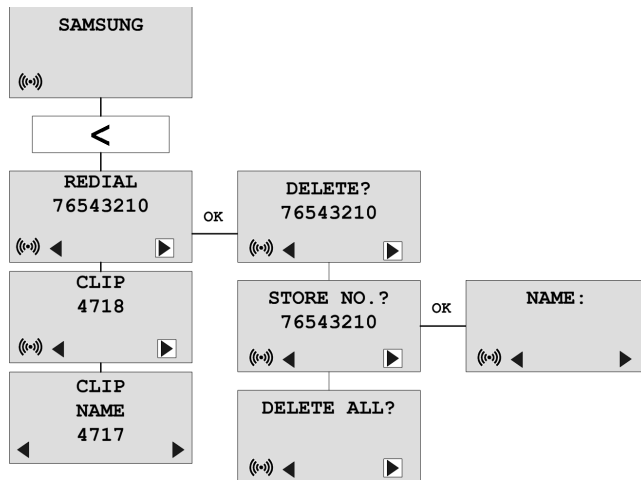

Book

Storing a number (maximum 24 digits) in the telephone book is done by pressing the number to be stored (in on-hook), then press the > key followed by the **OK** key. The book can store up to 65 numbers with name. Typing of the name and a confirmation is required. After storing the telephone will go back to standby mode. If the display shows "MEMORY FULL", it is necessary to delete one or more numbers from the telephone book.

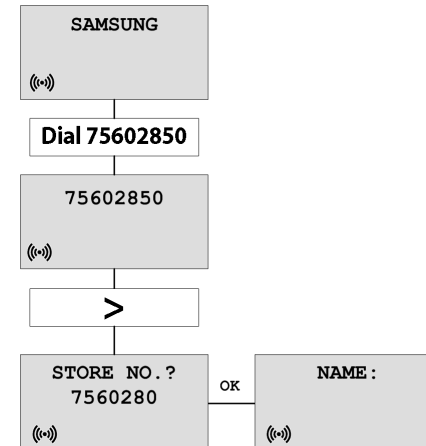

Read BOOK numbers: The telephone book is entered by pressing the > or . For quick search, press the first letter of the name (using **1-9**, please refer to the key functions). Call the displayed person by pressing the key. It is also possible to reach the telephone book menu in the main menu. Viewing and editing the telephone book can also be done while in conversation.

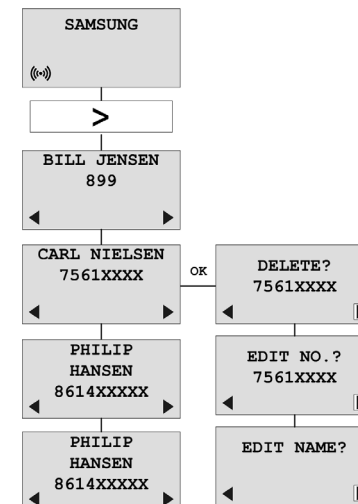

External Services

External Services are facilities placed in the main system, and only available if the handset is subscribed to a system. Under External Services you can find: Clip stack, Delete Clip Stack and your local Phone Book. The Local Phone Book is a common phone book for all handsets subscribed to the actual system, and all handsets subscribed to the system are listed in the Phone Book. Additional numbers can be added to the Phone Book by the system administrator.

MSF-Functions

MSF Functions are special functions, which are based on MSF (Message Service Function). The functions require special software in the main system.

Mail/Text Messages

Available in systems configured with the possibility of sending text messages.

At the reception of a text message the envelope icon  appears in the display. The envelope icon is indicating one or more unread messages.

The text message is shown in the display, and when the message is read the envelope icon will disappear. If the message contains a callback number, this will be displayed on the bottom line of the display. As long as the callback number is in the display, it is possible to activate the number by pressing the  key.

The first letter in the display, in the front of the time stamp, shows the message status: read (R), unread (N) or locked (L). Mails include a maximum of 72 letters or digits (2 display screens of 36 each). Call back number is maximum of 24 digits (or letters for E-Mail).

Fourteen messages (14) can be "stored" in the handset. When receiving a new message, the oldest unlocked message will be deleted. Locked messages will not automatically be overwritten, but can manually be deleted. Maximum 7 messages can be locked.

READ A MAIL MESSAGE

Press the **R** key followed by the **OK** key or enter the mail menu (in on-hook condition). If the message includes more than 36 letters or digits, the message will run over 2 display screens. Use the **>** key to scroll. To see the **sender** of the mail, press the **OK** key. To leave the mail, press the  key.

REPLY TO A MAIL MESSAGE

Open the mail by pressing the **R** key followed by the **OK** key, press the **OK** again and use the **<>** keys to find the reply feature, press the **OK** key and you are then able to reply the mail. After writing your reply press the **OK** key to confirm.

FORWARD A MAIL MESSAGE

Open the mail by pressing the **R** key followed by the **OK** key, press the **OK** again and use the **<>** keys to find the forward feature, press the **OK** key twice and you are then able to write the number on the receiver. Confirm with the **OK** key.

DELETE ALL MAIL MESSAGES

Open the mail stack by pressing the **R** key followed by the **OK** key, press the **OK** key again and use the **<>** keys to find the delete feature, press the **OK** key and all mail messages are deleted.

DELETE A MAIL MESSAGE

Open the mail by pressing the **R** key followed by the **OK** key, press the **OK** key again and use the **<>** keys to find the delete feature, press the **OK** key and all mail message is deleted.

LOCK/UNLOCK A MAIL MESSAGE

Open the mail by pressing the **R** key followed by the **OK** key, press the **OK** key again and use the **<>** keys to find the lock/unlock feature, press the **OK** key and the mail message is locked/unlocked.

WRITE A MAIL MESSAGE

To write a new mail message press **R** key, confirm with the **OK** key, press the **OK** key and write your message. To send the mail press the **OK** key, type the number of the receiver and confirm with the **OK** key.

If one or more mail messages are stored do as followed: Press the **R** key followed by the **>** key, confirm with the **OK** key and write your message. Press the **OK** key, type the number of the receiver and confirm with the **OK** key. The message is sent. **Note:** In case a sent message is not received, the sender will a message in the display.

Menu Structure

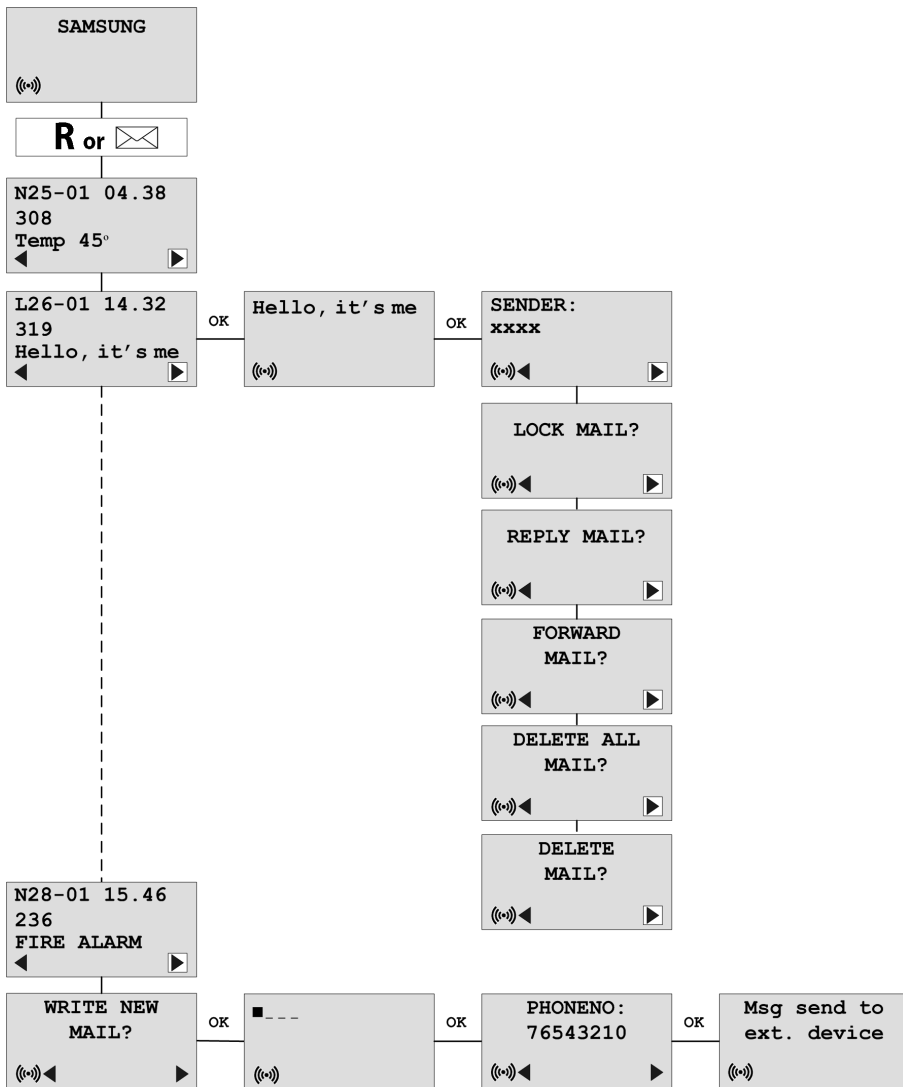

Menu Language

There are 6 predefined languages in the handset: English, German, French, Italian, Spanish and Dutch. Select the required language by accessing the menu, locate the language menu and select the required language by pressing the **OK** key. A seventh language might be present. If a seventh language is present this will be shown as "OPEN". The "OPEN" selection is a specific dealer language and is factory programmed.

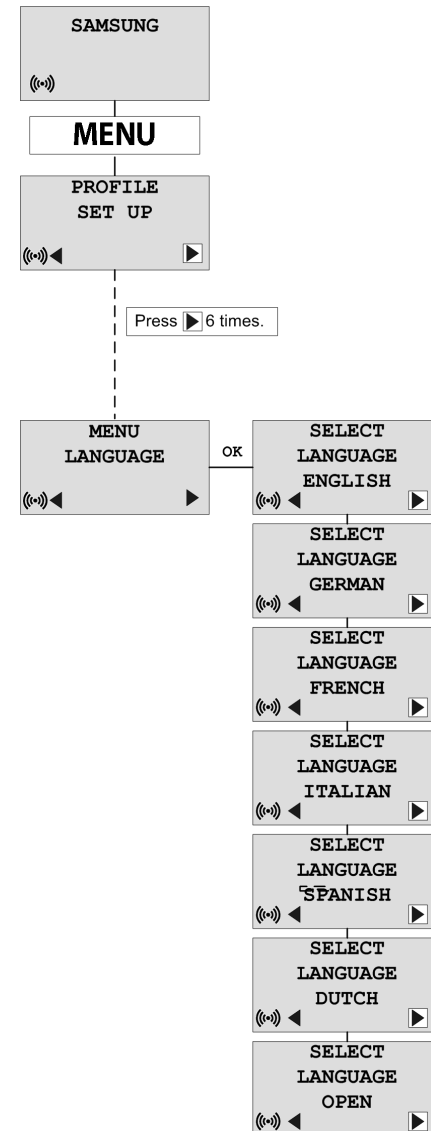

SHORTCUTS

SILENT: Press  #. No sounds. Display shows "SILENT".

KEY LOCKED: Press  *. Display shows "KEY LOCKED".

PHONE BOOK: Press > or  in standby.

Name search in the Phone Book: Press the first letter in the name and the > key afterwards.

Store a Number in the Phone Book: Press > key after the number (in on-hook).

REDIAL and **CLIP:** Press < key in standby.

MAIL: Press the **R** key while on-hook.

MUTE temporarily the ringer: Press the **OK** key when the telephone is ringing.

MUTE the microphone: Press the **OK** key when the telephone is off-hook.

PAUSE: Hold the * key for one second.

INFORMATION

TROUBLESHOOTING

PROBLEM	CHECK
The telephone freezes.	Remove and replace the battery pack. Press  to turn on the telephone.
The telephone does not ring.	Check whether the ringer is SILENT or the RINGER VOLUME is OFF.
The telephone cannot find a system ID at "SUBSCRIPTION CREATE".	Check whether the system is set to allow subscriptions.
The telephone cannot subscribe even if the system ID has been found.	Check if Access Code is necessary.
Not possible to turn on the telephone.	Check if battery is connected. If yes, charge the battery.
The telephone turn off when receiving a call and going off-hook.	Charge the battery. If still a problem change the battery as it might be defective.

ERROR INFORMATION

Improper function of the handset might be related to the installation of the Wireless system or failures related to the main system.

TECHNICAL INFORMATION

Approvals

Acoustics:	TBR 10
Electrical:	TBR 6 (DECT RF)
Access profile:	TBR 22 (GAP)
EMC:	ETS 300 329 (CE labeling)

Size and Weight

Size: 143 x 48 x 26 mm

Weight: 121 g including battery \pm 10 g

Capacity

Active talking time: 10 hours

Standby Time: 90 hours

SAFETY INSTRUCTIONS

Important Safety Instructions and Product Information

Before using your telephone equipment, you should always follow basic safety instruction to reduce the risk of fire, electrical shock and injury to persons, and damage to property.

- 1 Read and understand all instructions.
- 2 Follow all warnings and instructions including those marked on the product.
- 3 Unplug this product before cleaning. Do not use liquid cleaners or aerosol cleaners. Use damp cloth for cleaning.
- 4 Do not install the telephone equipment in the bathroom or near a wash bowl, kitchen sink, or laundry tub, in a wet basement, or near a swimming pool.
- 5 Slots or openings in the cabinet back and bottom of the equipment are provided for ventilation to protect it from over-heating. These openings must not be blocked or covered.
- 6 The product should be operated only from the type of power source indicated on the instructions. If you are not sure of the type of power supply, consult your dealer or local power company.
- 7 Do not overload wall outlets and extension cords as this can result in fire or electrical shock.
- 8 Never push objects of any kind into this product through cabinet slots as they may not touch dangerous voltage points or short out parts that could result in fire, electrical shock, or injury. Never spill liquid of any kind into this product.
- 9 To reduce the risk of electrical shock or burns, do not disassemble this product. Opening or removing covers may expose you to dangerous voltages, dan-

gerous electrical current, or other risks. Incorrect reassemble can cause electrical shock when the appliance is subsequently used. If the product needs repair, consult your dealer.

- 10 Refer servicing to qualified service personnel under the following conditions:

If liquid has been spilled into product.

If the product has been exposed to rain or water.

If the product does not operate normally when following the operating instructions in the manual. Adjust only those controls that are covered by the operation instructions. Improper adjustment of other controls may result in damage and will often require extensive work by qualified service personnel to restore the product to normal operation.

If the product has been dropped or the cabinet has been damaged.

If the product exhibits a distinct change in performance.

- 11 Avoid using the telephone during an electrical storm. There may be a risk of electrical shock from lightning.
- 12 Do not use the telephone to report a gas leak in the vicinity of the leak.
- 13 Do not place the base or charger near microwave ovens, radio equipment, or non-ground connected televisions. These appliances may cause electrical interference to the base or handset.
- 14 The charger must be placed on a hard, flat surface and connected to a functional 120 volt AC power net adapter and plug the adapter into the power outlet.
- 15 This telephone will not operate in the event of blackout. Please keep a back-up phone for emergencies.

Intrinsic Safety

Do not use the handset in conditions where there is a danger of electrically ignited explosions.

Exposure to Sunlight, Heat and Moisture

Do not expose the cordless phone to direct sunlight for long periods. Keep the cordless phone away from excessive heat and moisture.

Battery Disposal

Defective batteries must be returned to a collection point for chemical waste disposal.

Spare Parts and Accessories

Use only approved spare parts and accessories. The operation of non-approved parts cannot be guaranteed and may even cause damage.

Power Failure

In the event of a power failure or flat battery, you cannot use the handset to make or receive calls.

Battery Precautions

To reduce the risk of fire, injury or electrical shock, or property damage, and to properly dispose of batteries, please read and understand the following instructions:

THIS PRODUCT CONTAINS NIMH BATTERIES BATTERIES MUST BE RECYCLED OR DISPOSED OF PROPERLY. DO NOT DISPOSE OF IN MUNICIPAL WASTE.

- 1 Only use type 8474 3411 battery in the handset.
DO NOT use other rechargeable batteries or non-rechargeable batteries. The batteries could short-circuit and the battery shell may be damaged causing a hazardous condition.
- 2 Always follow basic safety precautions when using and disposing of batteries. Do not dispose of the batteries in a fire, cells may explode. Do not expose batteries to water. Check your local codes for special disposal instructions.
- 3 DO NOT USE ALKALINE OR LITHIUM BATTERIES IN THE HANDSET.
- 4 Periodically clean the charge contacts on both the charger and handset.
- 5 Exercise care in handling batteries in order not to short the batteries with conducting materials such as rings, bracelets, and keys. The batteries or conducting material may overheat and cause burns of fire.
- 6 Do not open or mutilate the batteries, released electrolyte is corrosive and may cause damage to the eyes or skin. The electrolyte may be toxic if swallowed.

- 7 During charging batteries heat up. This is normal and not dangerous.
- 8 Do not use non-Samsung charging devices. This could damage the batteries.

Notices and Cautions

NOTICES:

Before installing this equipment, users should ensure that it is permissible to be connected to the facilities of the local telecommunications company. The equipment must also be installed using an acceptable method of connection. The customer should be aware that compliance with the above conditions may not prevent degradation of service in some situations.

Repairs to certified equipment should be coordinated by a representative designated by the supplier. Any repairs or alterations made by the user to this equipment, or equipment malfunctions, may give the telecommunications company cause to request the user to disconnect the equipment.

Users should ensure for their own protection that the electrical ground connections of the power utility, telephone lines and internal metallic water pipe system, if present, are connected together. This precaution may be particularly important in rural areas.

CAUTIONS:

Users should not attempt to make such connections themselves, but should contact the appropriate electric inspection authority, or electrician, as appropriate.

If your telephone equipment causes harm to the telephone network, the telephone company may ask you to disconnect the system from the line until the problem has been corrected or they may discontinue your service temporarily. If possible, they will notify you in advance. But if advance notice is not practical, you should be notified as soon as possible. You will be informed of your right to file a complaint with the FCC.

Your telephone company may make changes in its facilities, equipment, operations, or procedures that could affect the proper functioning of your telephone system. If they do and it is possible, you will be notified in advance to give you the opportunity to maintain uninterrupted telephone service. If you experience trouble with this telephone system, disconnect it from the network until the problem has been corrected or until you are sure that the equipment is not malfunctioning.

NOTE: This equipment has been tested and found to comply with the limits for a class B digital device, pursuant to Part 15 of the FCC Rules. These limits are designed to provide reasonable protection against harmful interference in a res-

idential installation. This equipment generates, uses and can radiate radio frequency energy and, if not installed and used in accordance with the instructions, may cause harmful interference to radio communications. However, there is no guarantee that interference will not occur in a particular installation. If this equipment does cause harmful interference to radio or television reception, which can be determined by turning the equipment off and on, the user is encouraged to try to correct the interference by one or more of the following measures:

- 1 Reorient or relocate the receiving antenna.
- 2 Increase the separation between the equipment and receiver.
- 3 Connect the equipment into an outlet on a circuit different from that to which the receiver is connected.
- 4 Consult the dealer or an experienced radio/TV technician for help.

POWER OUTAGE: In the event of a power outage, your cordless telephone will not operate. The cordless telephone requires electricity for operation. You should have a telephone which does not require electricity available for use during power outages.

INFORMATION TO USER: The user's manual or instruction manual for an intentional or unintentional radiator shall caution the user that changes or modifications not expressly approved by the party responsible for compliance could void the user's authority to operate the equipment.

N O T E S
